

Answer **all** questions in the answer booklet provided. Please start each question on a new page. You are advised to show all working, where possible. Where an answer is incorrect, some marks may be given for a correct method, provided this is shown by written working. Solutions found from a graphic display calculator should be supported by suitable working, for example, if graphs are used to find a solution, you should sketch these as part of your answer.

1. [Maximum mark: 12]

For an ecological study, Ernesto measured the average concentration (y) of the fine dust, PM10, in the air at different distances (x) from a power plant. His data are represented on the following scatter diagram. The concentration of PM10 is measured in micrograms per cubic metre and the distance is measured in kilometres.

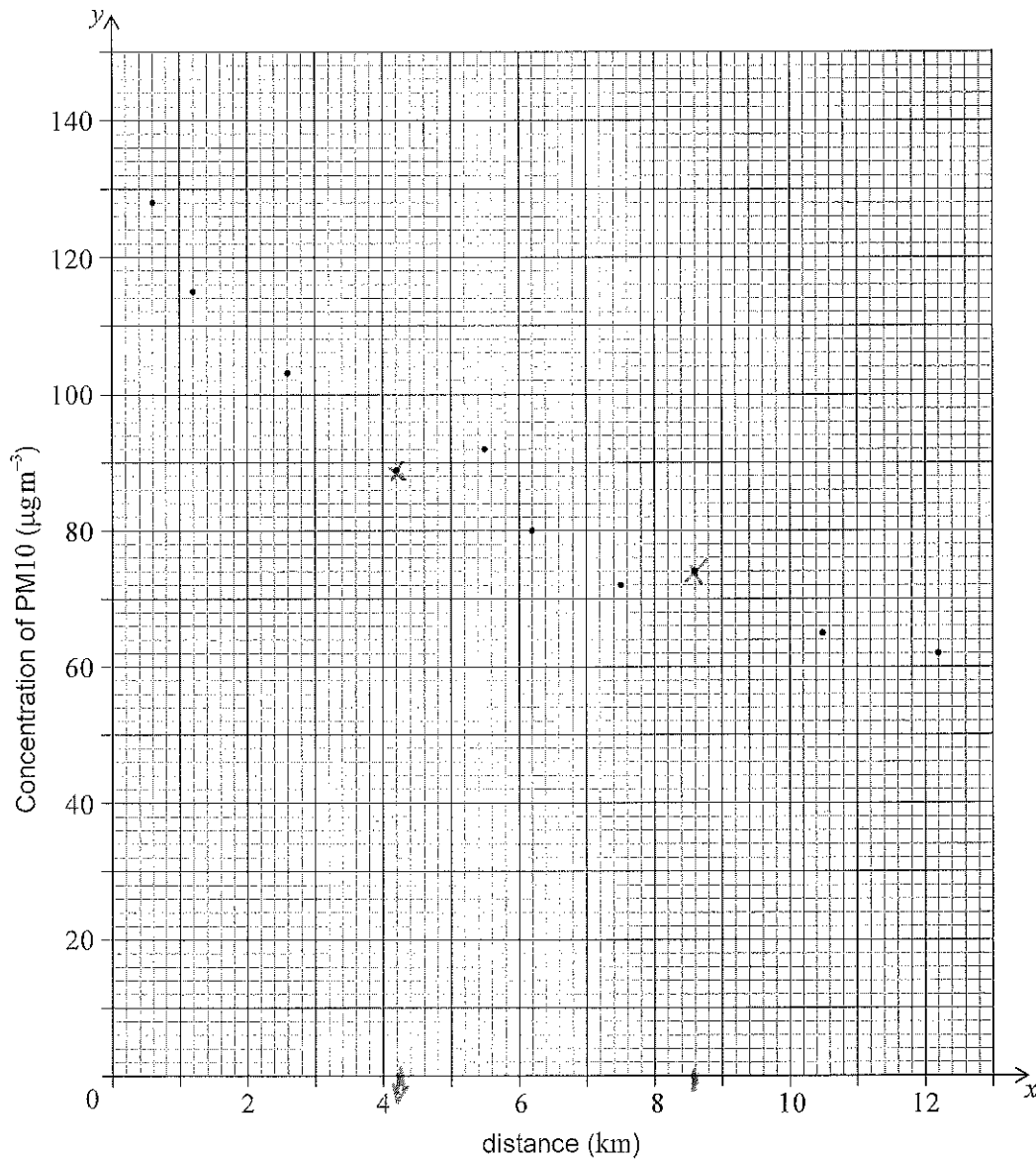

(This question continues on the following page)

(Question 1 continued)

His data are also listed in the following table.

Distance (x)	0.6	1.2	2.6	4.2	5.5	6.2	7.5	8.6	10.5	12.2
Concentration of PM10 (y)	128	115	103	89	92	80	72	b 74	65	62

- (a) Use the scatter diagram to find the value of a and of b in the table. [2]
- (b) Calculate
 - (i) \bar{x} , the mean distance from the power plant;
 - (ii) \bar{y} , the mean concentration of PM10;
 - (iii) r , the Pearson's product-moment correlation coefficient. [4]
- (c) Write down the equation of the regression line y on x . [2]

Ernesto's school is located 14 km from the power plant. He uses the equation of the regression line to estimate the concentration of PM10 in the air at his school.

- (d) (i) Calculate the value of Ernesto's estimate. [4]
- (ii) State whether Ernesto's estimate is reliable. Justify your answer.

a) $a = 4.2$ show work

$b = 74$

b) L_1, L_2 stat / Calc / 2 var stat / LinReg turn on

$\bar{x} = 5.91 \text{ Km}$

$\bar{y} = 88 \text{ mg/cm}^3$

$r = -0.956$

c) $y = -5.38955x + 119.852 \dots$

$y = -5.39x + 120$

d(i) $y = -5.38955(14) + 119.852 = 44.3984 = 44.4$

Turn over

d(ii) Ernesto's estimate is not reliable. This is an extrapolation (14 not within range of data domain of distances)

2. [Maximum mark: 18]

A group of students at Dune Canyon High School were surveyed. They were asked which of the following products: books (B), music (M) or films (F), they downloaded from the internet.

The following results were obtained:

- 100 students downloaded music;
- 95 students downloaded films;
- 68 students downloaded films and music; ✓
- 52 students downloaded books and music; ✓
- 50 students downloaded films and books;
- 40 students downloaded all three products; ✓
- 8 students downloaded books **only**;
- 25 students downloaded none of the three products.

- (a) Use the above information to complete a Venn diagram. [5]
- (b) Calculate the number of students who were surveyed. [2]
- (c) (i) On your Venn diagram, shade the set $(F \cup M) \cap B'$. Do not shade any labels or values on the diagram.
- (ii) Find $n((F \cup M) \cap B')$. *shown.* [3]
- (d) A student who was surveyed is chosen at random. Find the probability that
- (i) the student downloaded music;
 - (ii) the student downloaded books, given that they had not downloaded films;
 - (iii) the student downloaded at least two of the products. $(1 \text{ or } 2) \quad 12 + 10 + 40 + 28$ [6]

$$= \frac{90}{160}$$

Dune Canyon High School has 850 students.

$$\frac{100}{160} \times 850 = 531.25$$

(e) Find the expected number of students at Dune Canyon High School that downloaded music. [2]

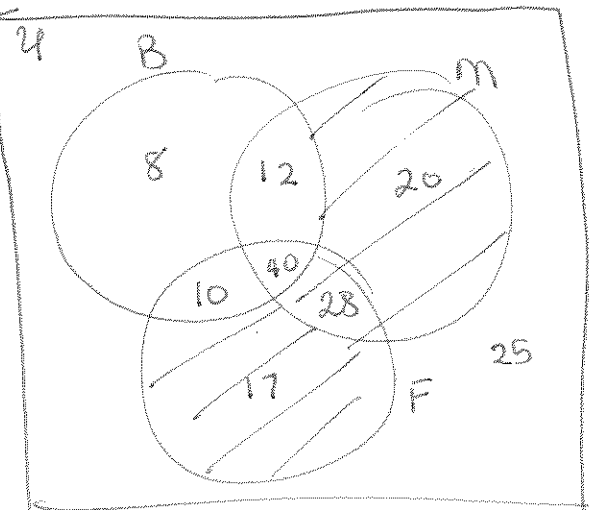

b) # students [2]

$$8 + 12 + 20 + 10 + 40 + 28 + 17 + 25 = 160 \text{ Show!}$$

(c) $n((F \cup M) \cap B')$

$$20 + 28 + 17 = 65$$

(d) (i) $\frac{100}{160} = \frac{5}{8}$

(ii) $P(B|F') = \frac{P(B \cap F')}{P(F')}$

$$\frac{20/160}{65/160} = \frac{20}{65}$$

3. [Maximum mark: 13]

A distress flare is fired into the air from a ship at sea. The height, h , in metres, of the flare above sea level is modelled by the quadratic function

$$h(t) = -0.2t^2 + 16t + 12, t \geq 0,$$



where t is the time, in seconds, and $t = 0$ at the moment the flare was fired.

(a) Write down the height from which the flare was fired. $t = 0$ 12 m [1]

(b) Find the height of the flare 15 seconds after it was fired. ✓ [2]

The flare fell into the sea k seconds after it was fired. $h(t) = 0$

(c) Find the value of k . [2]

(d) Find $h'(t)$. [2]

(e) (i) Show that the flare reached its maximum height 40 seconds after being fired.

(ii) Calculate the maximum height reached by the flare. [3]

The nearest coastguard can see the flare when its height is more than 40 metres above sea level.

(f) Determine the total length of time the flare can be seen by the coastguard. [3]

b) $h(15) = -0.2(15)^2 + 16(15) + 12 = 207\text{m}$

c) $h(t) = 0 \quad 0 = -0.2t^2 + 16t + 12$
Y2
Y1
intersect



d) $h'(t) = -0.4t + 16$

e) $h'(t) = -0.4t + 16 = 0$
 $-0.4t = -16$
 $t = \frac{16}{0.4} = \frac{160}{4} = 40 \text{ (sec)}$
or vertex $x = \frac{-b}{2a} = \frac{-16}{2(-0.2)}$

f) ii) $h(40) = -0.2(40)^2 + 16(40) + 12 = 332\text{m}$ (calc)

$h(t) = 40 = -0.2(t)^2 + 16(t) + 12$
Y1
Y2

$78.2 - 1.79$
 $= 76.4$

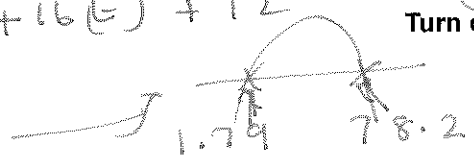

4. [Maximum mark: 19]

The Great Pyramid of Giza in Egypt is a right pyramid with a square base. The pyramid is made of solid stone. The sides of the base are 230 m long. The diagram below represents this pyramid, labelled VABCD.

V is the vertex of the pyramid. O is the centre of the base, ABCD. M is the midpoint of AB. Angle $ABV = 58.3^\circ$.

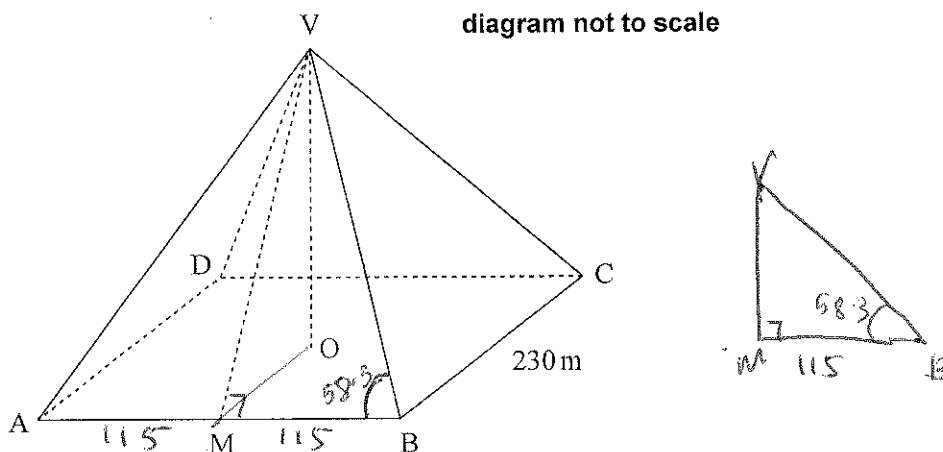

- (a) Show that the length of VM is 186 metres, correct to three significant figures. [3]
- (b) Calculate the height of the pyramid, VO. [2]
- (c) Find the volume of the pyramid. [2]
- (d) Write down your answer to part (c) in the form $a \times 10^k$ where $1 \leq a < 10$ and $k \in \mathbb{Z}$. [2]

Ahmad is a tour guide at the Great Pyramid of Giza. He claims that the amount of stone used to build the pyramid could build a wall 5 metres high and 1 metre wide stretching from Paris to Amsterdam, which are 430 km apart.

- (e) Determine whether Ahmad's claim is correct. Give a reason. [4]

(This question continues on the following page)

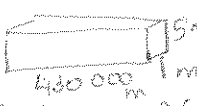
- a) $\tan 58.3 = \frac{VM}{115}$ $VM = 115 \tan 58.3 = 186.200 = \underline{186 m}$
- b) $115^2 + VO^2 = 186.200^2$
 $VO^2 = \sqrt{1862 - 115^2} = 146.188 = \underline{146 m}$
- c) $V = \frac{1}{3} A_{\text{base}} \times h(VO) = \frac{1}{3} \times 230^2 \times 146.188 = 2,577,785 = \underline{2,580,000 m^3}$
- d) $2.58 \times 10^6 m^3$
- e) Volume of wall  $= 430000 \times 5 \times 1 = 2,150,000 m^3$
 Vol pyramid $>$ Vol wall. Yes correct.

(Question 4 continued)

Ahmad and his friends like to sit in the pyramid's shadow, ABW, to cool down. At mid-afternoon, $BW = 160\text{ m}$ and angle $ABW = 15^\circ$.

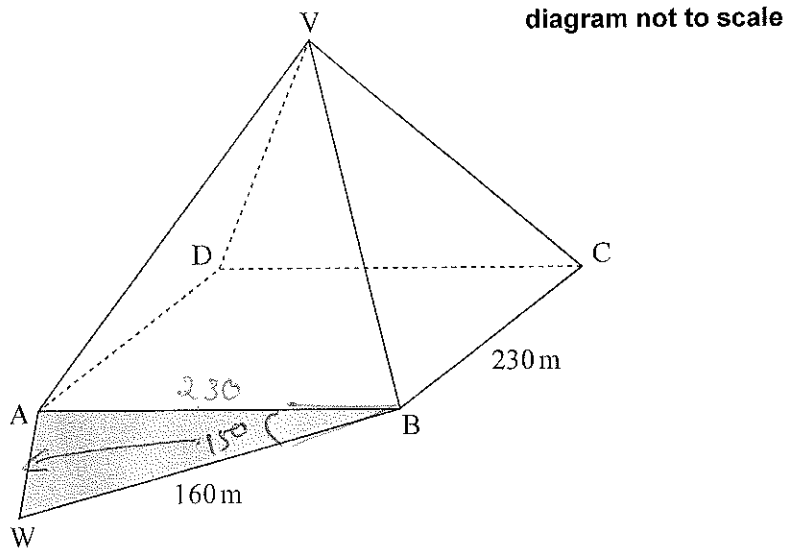

- (f) (i) Calculate the length of AW at mid-afternoon.
 (ii) Calculate the area of the shadow, ABW, at mid-afternoon.

[6]

cosine rule

$$f(i) \quad AW^2 = 230^2 + 160^2 - 2(230)(160)\cos 15^\circ$$

$$AW = 86.0689 = \boxed{86.1\text{ m}}$$

$$ii) \quad \text{Area} = \frac{1}{2}(230)(160)\sin 15 = 4762.27 \dots$$

$$= \boxed{4760\text{ m}^2}$$

5. [Maximum mark: 16]

Antonio and Barbara start work at the same company on the same day. They each earn an annual salary of 8000 euros during the first year of employment. The company gives them a salary increase following the completion of each year of employment. Antonio is paid using plan A and Barbara is paid using plan B.

Plan A: The annual salary increases by 450 euros each year. $+450$

Plan B: The annual salary increases by 5% each year. 1.05

$u_n = 21(n-1)$
 $u_n = 21(n-1) \cdot 1.05^{n-1}$

- (a) Calculate
 - (i) Antonio's annual salary during his second year of employment;
 - (ii) Barbara's annual salary during her second year of employment. [3]
- (b) Write down an expression for
 - (i) Antonio's annual salary during his n th year of employment;
 - (ii) Barbara's annual salary during her n th year of employment. [4]
- (c) Determine the number of years for which Antonio's annual salary is greater than or equal to Barbara's annual salary. [2]

Both Antonio and Barbara plan to work at the company for a total of 15 years.

- (d) (i) Calculate the total amount that Barbara will be paid during these 15 years.
- (ii) Determine whether Antonio earns more than Barbara during these 15 years. [7]

a) $8000 + 450 = 8450 \text{ Euro}$ (i) $8000 \times 1.05 = 8400 \text{ Euro}$

b) $8000 + 450(n-1) = 450n + 7550$

c) $8000 + 450(n-1) \geq 8000(1.05)^{n-1}$
 $n = 6 \text{ years (complete)}$

d) (i) Barbara: $S_{15} = \frac{8000(1.05^{15} - 1)}{1.05 - 1} = 172629 = 173,000 \text{ Euro}$

(ii) Antonio: $S_{15} = \frac{15}{2} (2 \times 8000 + (15-1)450) = 167250 = 167,000 \text{ Euro}$

Antonio does not earn more than Barbara. Total salary is less than hers.

n	y_1	y_2
5	9800	9724.1
6	10250	10210
7	10700	10721

6. [Maximum mark: 12]

A function, f , is given by

$$f(x) = 4 \times 2^{-x} + 1.5x - 5.$$

- (a) Calculate $f(0)$. [2]
- (b) Use your graphic display calculator to solve $f(x) = 0$. [2]
- (c) Sketch the graph of $y = f(x)$ for $-2 \leq x \leq 6$ and $-4 \leq y \leq 10$, showing the x and y intercepts. Use a scale of 2 cm to represent 2 units on both the horizontal axis, x , and the vertical axis, y . [4]

The function f is the derivative of a function g . It is known that $g(1) = 3$.

- (d) (i) Calculate $g'(1)$. [4]
- (ii) Find the equation of the tangent to the graph of $y = g(x)$ at $x = 1$. Give your answer in the form $y = mx + c$.

a) $f(0) = 4 \times 2^{-0} + 1.5(0) - 5 = 4 + 0 - 5 = -1$

b) $y_1 = 4 \times 2^{-x} + 1.5x - 5 = 0$

$x = 3$ $x = -0.538$ 2nd calc int.

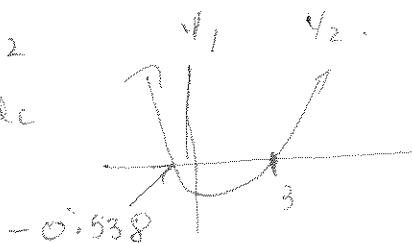

c) Actual graph. Ruler.

y_1, y_2 taken:

$(1, -1.5)$
 $(2, -1)$

y int $\rightarrow x = 0$ $(0, -1)$

d(i) $g'(1) = f(1) = \frac{4}{2} + 1.5 - 5 = -3 + 1.5 = -1.5$

(ii) grad. tangent = $-\frac{3}{2}$ $(1, 3)$

$3 = -\frac{3}{2}(1) + b$

$3 = -\frac{3}{2} + b$

$3 + \frac{3}{2} = b = \frac{9}{2}$

$y = -\frac{3}{2}x + \frac{9}{2}$

$y = -1.5x + 4.5$

Candidate session number: / Numéro de session du candidat : / Número de convocatoria del alumno:

						-				
--	--	--	--	--	--	---	--	--	--	--

Candidate name: / Nom du candidat : / Nombre del alumno:

--	--	--	--	--	--	--	--	--	--	--

Question number: / Numéro de la question : / Número de la pregunta:

